



CX series stainless steel cylinders, have been designed respecting ISO 15552 norm. They are entirely made in stainless steel and their usage is particularly suitable in harsh atmospheres, like the naval, pharmaceutical and food industry. Bores are between Ø32 to 125 mm.

Le vérin série CX répond exactement à la norme ISO 15552.
Il est prévu pour être utilisé dans des ambiances spéciales: pharmaceutique, navale, alimentaire.
Les tailles disponibles vont du 32 au 125 mm.

cilindri della serie CX sono stati realizzati rispettando la normativa ISO 15552.
Sono interamente realizzati in acciaio inox e particolarmente adatti in ambienti particolari e aggressivi come: navale, farmaceutico, alimentare. Gli alesaggi sono compresi tra Ø32 e 125 mm.

ORDERING CODE / CODIFICATION / CHIAVE DI CODIFICA

C X 0 0 1 0 0 0 0 0 0

Stroke / Course / Corsa

Ø cylinder / Ø vérin / Ø cilindro

VERSION / VERSION / VERSIONE

01 = double acting cushioned magnetic / **double effet amorti magnétique** / doppio effetto ammortizzato magnetico

03 = through rod cushioned magnetic / **tige traversante amorti magnétique** / stelo passante ammortizzato magnetico

16 = All stainless steel AISI 316, double acting cushioned magnetic / **Tout en acier inoxydable AISI 316, double effet amorti magnétique** / Tutto in acciaio inox AISI 316, doppio effetto ammortizzato magnetico

17 = All stainless steel AISI 316, through rod cushioned magnetic / **Tout en acier inoxydable AISI 316, tige traversante amorti magnétique** / Tutto in acciaio inox AISI 316, stelo passante ammortizzato magnetico

VERSION / VERSION / VERSIONE

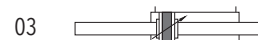

TECHNICAL DATA / DONNÉES TECHNIQUES / DATI TECNICI

Sizes / Alésage / Alesaggi	Ø32-40-50-63-80-100-125
Standard strokes / Course standard / Corse standard	mm 25-50-80- 100-125-160-200-250-320-350-400-500-600-700-800-900-1000
Fluid / Fluide / Fluido	Lubricated or non lubricated air / Air avec ou sans lubrification / Aria con o senza lubrificazione
Operating temperature range / Température d'utilisation / Temperatura di esercizio	Polyurethane / Polyuréthane / Poliuretano: -20°C + 80°C Viton: -10°C + 150°C
Max operating pressure / Pression max d'utilisation / Pressione massima di esercizio	10 bar
Force / Force / Forze sviluppate	Technical informations page / Page informations techniques / Pagina dati tecnici
Air consumption / Consommation d'air / Consumo aria	Technical informations page / Page informations techniques / Pagina dati tecnici

COMPONENTS / COMPOSANTS / COMPONENTI

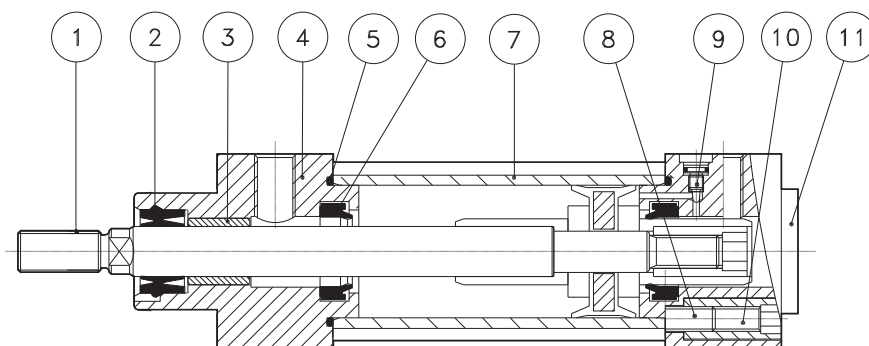

pos. description / description / descrizione	material / matériel / materiale
1 rod / tige / stelo	stainless steel AISI 316 / acier inox 316 / acciaio inox 316
2 rod seal / joints tige / guarnizione stelo	polyurethane / polyuréthane / poliuretano
3 guide bush / bague guidage / bussola guida	bronze / bronze / bronzo
4 front cap / nez avant / testata anteriore	stainless steel AISI 304 / acier AISI 304 / acciaio AISI 304
5 o-ring / joint torique	NBR
6 cushion seal / joint d'amortissement / guarnizione ammortizzo	polyurethane / polyuréthane / poliuretano
7 tube / tube / tube	stainless steel AISI 304 / acier AISI 304 / acciaio inox 304
8 tie rod / tirant / tirante	stainless steel AISI316 / acier inox 316 / acciaio inox 316
9 regulator cushion screw / vis reg.amortis. / vite reg. ammortizzo	stainless steel AISI 316 / acier inox 316 / acciaio inox 316
10 fixing cap screw / vis serrage nez / vite serraggio testata	stainless steel AISI 316 / acier inox 316 / acciaio inox 316
11 rear cap / fond arrière / testata posteriore	stainless steel AISI 304 / acier AISI 304 / acciaio inox 304

Double acting magnetic cushioned
Double effet magnétique amorti
Doppio effetto magnetico ammortizzato

CODE: CX011.Ø.mm

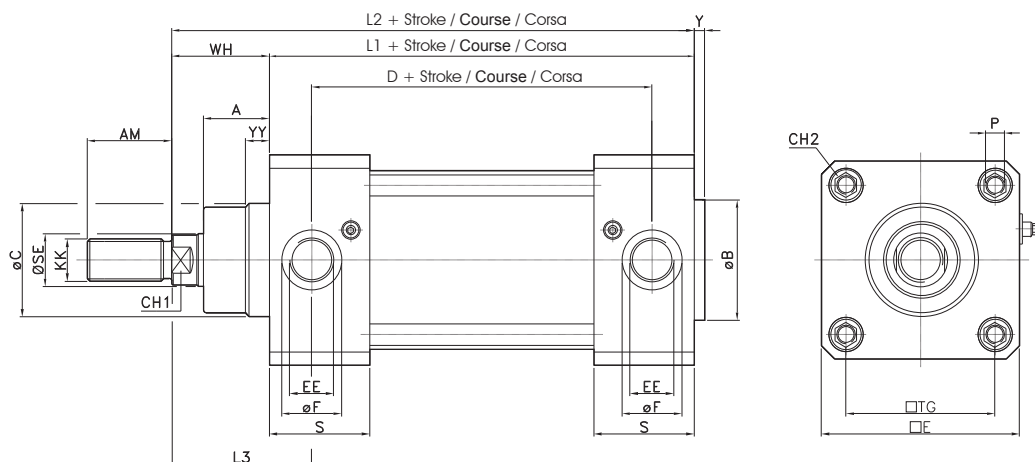

Ø	A	AM	B	C	D	E	EE	F	Y	YY	KK	L1	L2	L3	P	S	SE	TG	WH	CH1	CH2
32	18	22	30	30	67	50	G1/8"	16	4	9	M10x1.25	95	121	39.5	M6	30.8	12	32.5	26	10	6
40	22	24	35	35	77	55	G1/4"	19	4	9	M12x1.25	105	135	44	M6	33	16	38	30	13	6
50	25.5	32	40	40	78	65	G1/4"	19	4	9	M16x1.5	106	143	51	M8	33.7	20	46.5	37	16	8
63	25	32	45	45	89	75	G3/8"	22.7	4	9	M16x1.5	121	158	53	M8	38	20	56.5	37	16	8
80	35	40	45	45	96	95	G3/8"	22.7	4	9	M20x1.5	128	174	62	M10	40	25	72	46	21	10
100	38	40	55	55	102	110	G1/2"	28	4	9	M20x1.5	138	189	69	M10	43.5	25	89	51	21	10
125	46	54	60	60	124	139	G1/2"	28	6	10	M27x2	160	225	83	M12	53	32	110	65	27	12

Double acting magnetic through rod
Double effet magnétique tige traversante
Doppio effetto magnetico stelo passante

CODE: CX031.Ø.mm

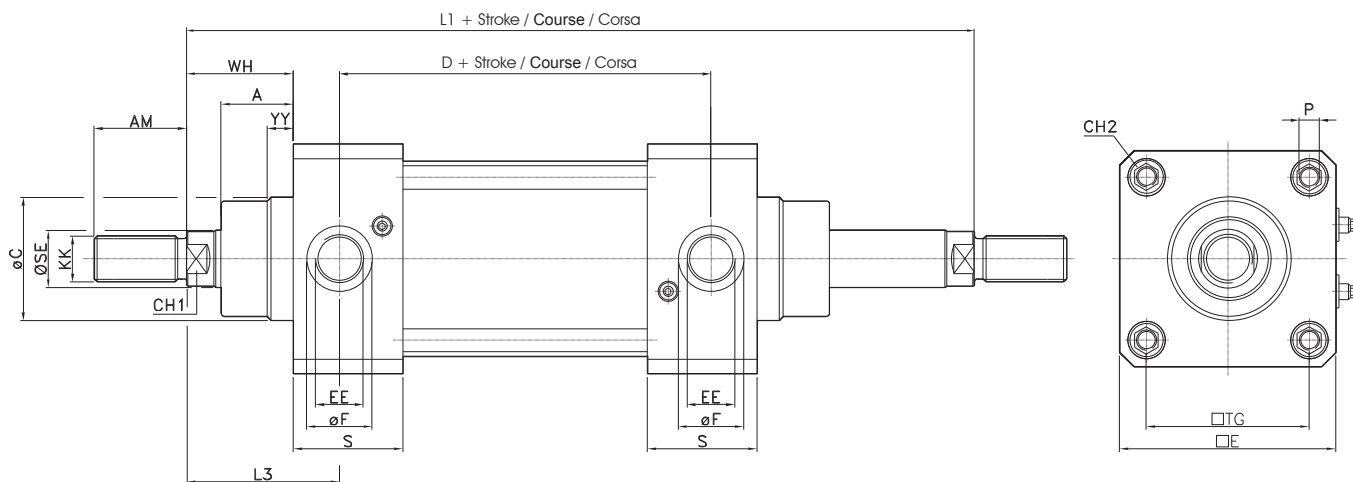

Ø	A	AM	C	D	E	EE	F	YY	KK	L1	L3	P	S	SE	TG	WH	CH1	CH2
32	18	22	30	67	50	G1/8"	16	9	M10x1.25	147	39.5	M6	30.8	12	32.5	26	10	6
40	22	24	35	77	55	G1/4"	19	9	M12x1.25	165	44	M6	33	16	38	30	13	6
50	25.5	32	40	78	65	G1/4"	19	9	M16x1.5	180	51	M8	33.7	20	46.5	37	16	8
63	25	32	45	89	75	G3/8"	22.7	9	M16x1.5	195	53	M8	38	20	56.5	37	16	8
80	35	40	45	96	95	G3/8"	22.7	9	M20x1.5	220	62	M10	40	25	72	46	21	10
100	38	40	55	102	110	G1/2"	28	9	M20x1.5	240	69	M10	43.5	25	89	51	21	10
125	46	54	60	124	139	G1/2"	28	11	M27x2	290	83	M12	53.2	32	110	65	28	12

**PEDESTAL
EQUERRE
PIEDINO**

Material: Stainless steel AISI 316
Matière: Inox AISI 316
Materiale: Inox AISI 316

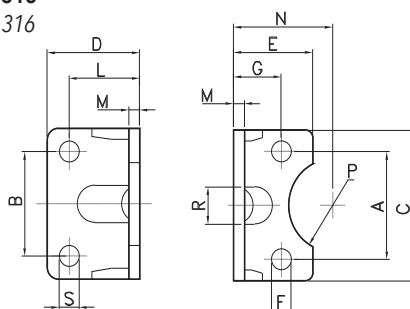
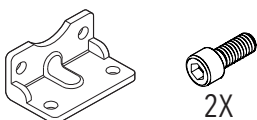

CODE	Ø
AR4169032-V	32
AR4169040-V	40
AR4169050-V	50
AR4169063-V	63
AR4169080-V	80
AR4169100-V	100
AR4169125-V	125

Ø	A	B	C	D	E	F	G	L	M	N	P	R	S
32	32.5	32	45	35	30	7	15.75	24	4	32	15	11	7
40	38	36	52	36	30	7	17	28	4	36	17.5	15	9
50	46.5	45	65	47	36	9	21.75	32	5	45	20	16	9
63	56.5	50	75	45	35	9	21.75	32	5	50	22.5	18	9
80	72	63	95	55	47	11	27	41	6	63	22.5	17	12
100	89	75	115	57	53	11	26.5	41	6	71	27.5	24	14
125	110	90	140	70	70	14	35	45	8	90	30	-	16

**FLANGE
BRIDE
FLANGIA**

Material: Stainless steel AISI 316
Matière: Inox AISI 316
Materiale: Inox AISI 316

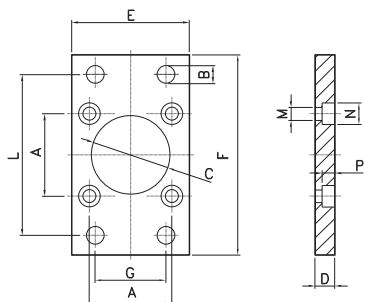
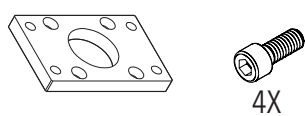

CODE	Ø
AR4168032-V	32
AR4168040-V	40
AR4168050-V	50
AR4168063-V	63
AR4168080-V	80
AR4168100-V	100
AR4168125-V	125

Ø	A	B	C	D	E	F	G	L	M	N	P
32	32.5	7	30	10	45	80	32	64	6.5	10.5	6.5
40	38	9	35	10	52	90	36	72	6.5	10.5	6.5
50	46.5	9	40	12	65	110	45	90	8.5	13.5	8.5
63	56.5	9	45	12	75	120	50	100	8.5	13.5	8.5
80	72	12	45	16	95	150	63	126	10.5	16.5	10.5
100	89	14	55	16	115	170	75	150	10.5	16.5	10.5
125	110	16	60	20	140	205	90	180	13.5	20	12.5

**FEMALE HINGE
CHAPE ARRIERE
CERNIERA FEMMINA**

Material: Stainless steel AISI 316
Matière: Inox AISI 316
Materiale: Inox AISI 316

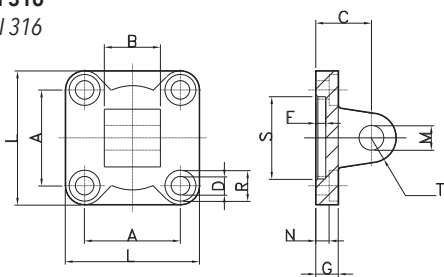
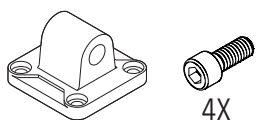

CODE	Ø
AR4165032-V	32
AR4165040-V	40
AR4165050-V	50
AR4165063-V	63
AR4165080-V	80
AR4165100-V	100
AR4165125-V	125

Ø	A	B	C	D	F	G	L	M	N	R	S	T
32	32.5	26	22	6.6	5	9	45	10	5.5	11	30	10
40	38	28	25	6.6	5	9	52	12	5.5	11	35	12
50	46.5	32	27	9	5	11	65	12	6.5	15	40	12
63	56.5	40	32	9	5	11	75	16	6.5	15	45	16
80	72	50	36	11	5	14	95	16	10	18	45	16
100	89	60	41	11	5	14	115	20	10	18	55	20
125	110	70	50	14	7	20	140	25	10	20	60	25

**FEMALE HINGE
CHAPE ARRIERE
CERNIERA FEMMINA**

Material: Stainless steel AISI 316
Matière: Inox AISI 316
Materiale: Inox AISI 316

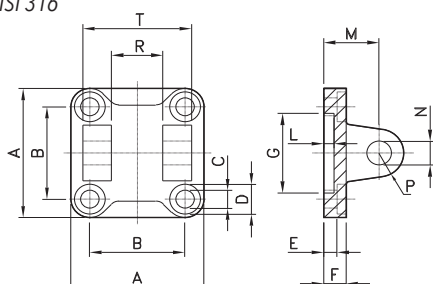
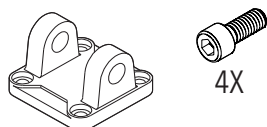

CODE	Ø
AR4164032-V	32
AR4164040-V	40
AR4164050-V	50
AR4164063-V	63
AR4164080-V	80
AR4164100-V	100
AR4164125-V	125

Ø	A	B	c	D	E	F	G	L	M	N	p	R	T
32	45	32.5	6.6	11	5.5	9	30	5	22	10	10	26	45
40	52	38	6.6	11	5.5	9	35	5	25	12	12	28	52
50	65	46.5	9	15	6.5	11	40	5	27	12	12	32	60
63	75	56.5	9	15	6.5	11	45	5	32	16	16	40	70
80	95	72	11	18	10	14	45	5	36	16	16	50	90
100	115	89	11	18	10	14	55	5	41	20	20	60	110
125	140	110	14	20	10	20	60	7	50	25	25	70	130

SQUARE JOINT
ARTICULATION ARRIERE D'EQUERRE
ARTICOLAZIONE A SQUADRA

Material: Stainless steel AISI 316
Matière: Inox AISI 316
Materiale: Inox AISI 316

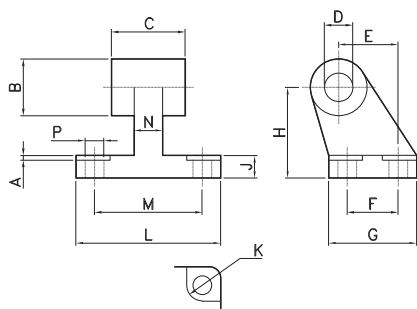
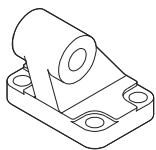

CODE	Ø
AR4166032	32
AR4166040	40
AR4166050	50
AR4166063	63
AR4166080	80
AR4166100	100
AR4166125	125

Ø	A	B	C	D	E	F	G	H	J	K	L	M	N	P
32	1.6	20	26	10	21	18	31	32	8	11	51	38	10	6.6
40	1.6	22	28	12	24	22	35	36	10	11	54	41	15	6.6
50	1.6	26	32	12	33	30	45	45	12	15	65	50	16	9
63	1.6	30	40	16	37	35	50	50	14	15	67	52	16	9
80	2.5	30	50	16	47	40	60	63	14	18	86	66	20	11
100	2.5	38	60	20	55	50	70	71	17	18	96	76	20	11
125	3.2	45	70	25	70	60	90	90	20	20	124	94	30	14

PIVOT FOR HINGE
AXE ARTICULATION ARRIERE FEMELLE
PERNO PER CERNIERA

Material: Stainless steel AISI 316
Matière: Inox AISI 316
Materiale: Inox AISI 316

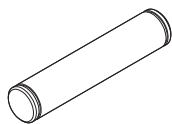

2X

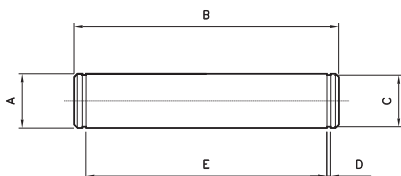

CODE	Ø
AR4167032	32
AR4167040	40
AR4167050	50
AR4167063	63
AR4167080	80
AR4167100	100
AR4167125	125

Ø	A	B	C	D	E
32	10	53	9.6	1.1	46
40	12	60	11.5	1.1	53
50	12	68	11.5	1.1	61
63	16	78	15.2	1.1	71
80	16	98	15.2	1.1	91
100	20	118	19	1.3	111
125	25	139	23.9	1.3	132

ROD ENDS
CHAPE DE TIGE ROTULEE
TESTA A SNODO

Material: Stainless steel AISI 316
Matière: Inox AISI 316
Materiale: Inox AISI 316

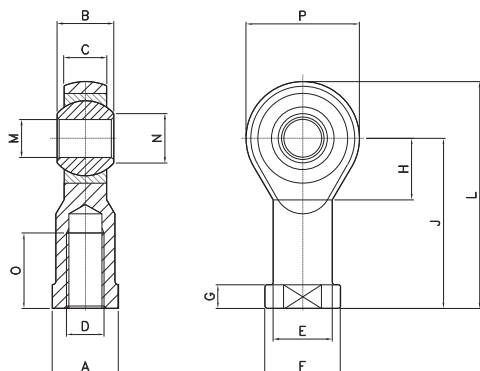

CODE	Ø
AR4250	32
AR4251	40
AR4252	50-63
AR4253	80-100
AR4254	125

Ø	A	B	C	D	E	F	G	H	J	L	M	N	O	P
32	17	14	10.5	M10x1.25	15	19	6.5	15	43	57	10	12.9	20	28
40	19	16	12	M12x1.25	17.5	22	6.5	17	50	66	12	15.4	22	32
50-63	22	21	15	M16x1.5	22	27	8	23	64	85	16	19.3	28	42
80-100	30	25	18	M20x1.5	27.5	34	10	27	77	102	20	24.3	33	50
125	41	37	25	M27x2	40	50	15	36	110	145	30	34.8	51	70

YOKE WITH PIVOT
CHAPE DE TIGE AVEC AXE
FORCELLA CON PERNO

Material: Stainless steel AISI 303
Matière: Inox AISI 303
Materiale: Inox AISI 303

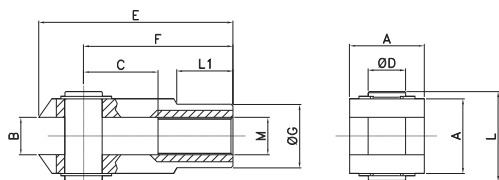
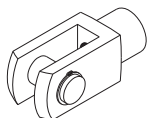

CODE	Ø
AR4218	32
AR4219	40
AR4220	50-63
AR4221	80-100
AR4222	125

Complete of pivot and seeger
Chape + axe + circlips
Completo di perno e seeger

Ø	A	B	C	D	E	F	G	M	L	L1
32	20	10	20	10	52	40	18	M10x1.25	25	15
40	24	12	24	12	62	48	20	M12x1.25	30	18
50/63	32	16	32	16	83	64	26	M16x1.5	39	24
80/100	40	20	40	20	105	80	34	M20x1.5	48	30
125	55	30	54	30	148	110	48	M27x2	65	38

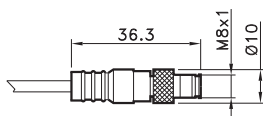
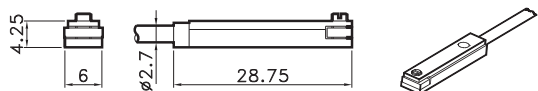

4= black / **noire** / nero
1= brown / **brun** / marrone
3= blue / **bleu** / azzurro

T SWITCH / **CAPTEUR EN T** / *SENSORE AT*

CODE	
AR4023010	REED (MT.2,5) / REED (MT.2,5) / REED (MT.2,5)
AR4023020	HALL (MT.2,5) / HALL (MT.2,5) / HALL (MT.2,5)
AR4023110	REED + M8 (CM 30) / REED + M8 / REED + M8 (CM 30)
AR4023120	HALL + M8 (CM 30) / HALL + M8 / HALL + M8 (CM 30)

For technical data see page 1.62
Pour les données techniques, voir page 1.62
Per i dati tecnici vedere pag. 1.62

ADAPTOR FOR T SWITCH
ADAPTATEUR CAPTEUR EN T
ADATTATORE SENSORE AT

Material: Aluminium
Matière: Aluminium
Materiale: Alluminio

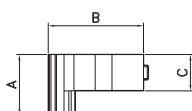
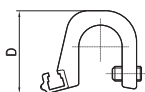
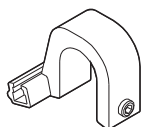

CODE	Ø
AR420032	32-40
AR420050	50-63
AR420080	80-100
AR4200125	125

Ø	A	B	C	D
32-40	25	30	15	20
50-63	25	35	15	26
80-100	25	38	15	30
125	25	40	15	35